

Sfero Döküm / Ductile Iron

T-1437

Genel Özellikler / General Specifications

Çalışma Sıcaklık Aralığı / Working Temperature : -10 ... +110 °C (16 Bar)
"Pik Kullanım Sıcaklığıdır"

Standartlar / Standards

Sertifikalar / Certificates :
Tasarım / Design : TS EN 1171
Flanş Boyutları / Flange Dimensions : TS EN 1092-2 (PN 16)
Alından Alına Boyutlar / Face to Face Dimensions : TS EN 558 (Seri 14)
Testler / Tests : TS EN 12266-1

Uygulamalar / Applications

Sıcak ve soğuk su sistemleri,
asit ve alkali özelliği bulunmayan sıvı akışkanlar
Hot and cold water systems, non-acidic and
non-flammable liquid fluids



Kullanılan komponentler içme suyuına uygundur

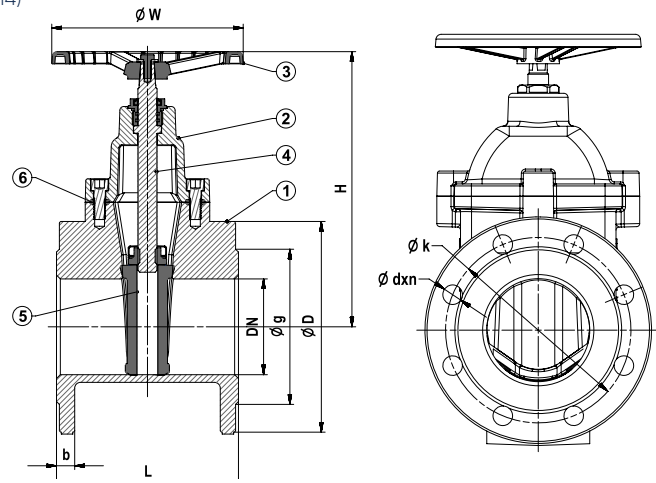

Malzeme Özellikleri Material Specifications

No	Parça Adı / Part Name	Malzeme / Material
1	Gövde / Body	Body GGG 40 - EN GJS 400-15 - Sfero Döküm / Ductile Iron
2	Kapak / Bonnet	Bonnet GGG 40 - EN GJS 400-15 - Sfero Döküm / Ductile Iron
3	Volan / Handwheel	GG 25 - EN GJL 250 - PİK Döküm / Cast Iron
4	Mil / Stem	X20Cr13 - AISI420 - Paslanmaz Çelik / Stainless Steel
5	Sürgü / Wedge	GGG 40 - EN GJS 400-15 - Sfero Döküm + Kauçuk Kaplı / Ductile Iron + Rubber Coated
6	Conta / Gasket	EPDM - NBR



Ölçüler Dimensions

Anma Basıncı Nominal Pressure	16 Bar										
Anma Çapı Nominal Diameter	DN	40	50	65	80	100	125	150	200	250	300
Vana Boyutları Valve Dimensions	L	140	150	170	180	190	200	210	230	250	270
	H	170	180	230	245	265	355	400	490	615	700
	W	160				200	250		315		
	D	150	165	185	200	220	250	285	340	405	460
	k	110	125	145	160	180	210	240	295	355	410
	g	84	99	118	132	156	184	211	266	319	370
	b	18	20		22	24	26		30	32	
	dxn	19x4				19x8			23x8	23X12	28x12
Ağırlık Weight	Kg	9	10	15	17	23	37	45	80	109	145

* Boya ve conta malzemeleri WRAS onaylıdır. / Paint and gasket materials are WRAS approved.