

Pirinç Dövme / Forced Brass

T-2260

Genel Özellikler / General Specifications

Çalışma Sıcaklık Aralığı / Working Temperature : -10... +90 °C (10 Bar)

Standartlar / Standards

Sertifikalar / Certificates :

Tasarım / Design : TS 7817

Diş Standardı / Thread Standard : EN ISO 228-1

Testler / Tests : TS EN 12266-1

Uygulamalar / Applications

Sıcak ve soğuk su sistemleri
Hot and cold water systems

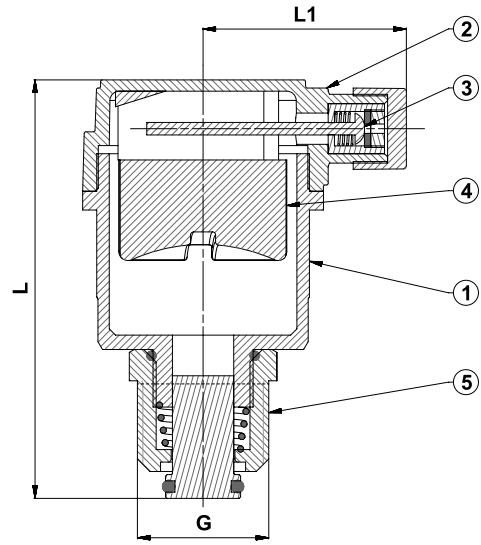

Malzeme Özellikleri Material Specifications

No	Parça Adı / Part Name	Malzeme / Material
1	Gövde / Body	CuZn40Pb2 - CW617N - Pirinç Dövme / Forced Brass
2	Kapak / Bonnet	CuZn40Pb2 - CW617N - Pirinç Dövme / Forced Brass
3	Emniyet Subabı / Safety Valve	Ebonit / Ebonite
4	Şamandıra / Float	Ebonit / Ebonite
5	Çek Vana / Check Valve	CuZn40Pb2 - CW617N - Pirinç Dövme / Forced Brass



Ölçüler Dimensions

Anma Basıncı Nominal Pressure	10 Bar	
Vana Boyutları Valve Dimensions	G	1 / 2"
	L	71
	L1	29
Ağırlık Weight	Kg	0.13