

Karbon Çelik Döküm / Cast Carbon Steel

# T-0430

Genel Özellikler / General Specifications

Çalışma Sıcaklık Aralığı / Working Temperature : -10 ... +110 °C (16 Bar)  
"Pik Kullanım Sıcaklığıdır"

Standartlar / Standards

Sertifikalar / Certificates :

Flanş Boyutları / Flange Dimensions : TS EN 1092-2 (PN 16)

Testler / Tests : TS EN 12266-1

Uygulamalar / Applications

Deniz suyu (paslanmaz çelik), kondens sistemleri  
(paslanmaz çelik), arıtma sistemleri, HVAC sistemleri  
Sea water(stainless steel), condensation systems  
(stainless steel), purification systems, HVAC systems

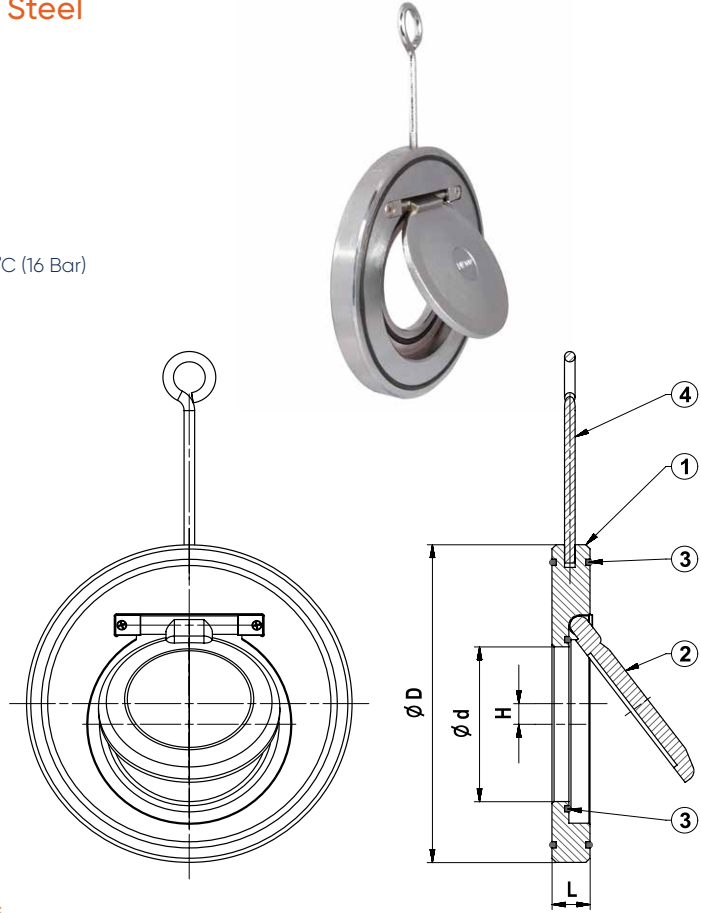

## Malzeme Özellikleri Material Specifications

No	Parça Adı / Part Name	Malzeme / Material
1	Gövde / Body	GS-C 25 - GP240GH Karbon Çelik Döküm + Nikel Kaplama / Cast Carbon Steel + Nickel Plated (T-0430)
2	Klape / Disc	GS-C 25 - GP240GH Karbon Çelik Döküm + Nikel Kaplama / Cast Carbon Steel + Nickel Plated (T-0430)
3	O-Ring / O-Ring	EPDM - NBR
4	Mapa / Eye Bolt	St 37 - Çelik + Nikel Kaplama / Steel + Nickel Plated



## Ölçüler Dimensions

Anma Basıncı Nominal Pressure	16 Bar														
Anma Çapı Nominal Diameter	DN	40	50	65	80	100	125	150	200	250	300	350	400	500	600
Vana Boyutları Valve Dimensions	ØD	92	107	127	142	162	192	218	273	329	384	444	491	610	724
	Ød	22	32	40	54	70	92	114	154	200	235	280	316	405	486
	L	14			18			20	22	26	28	38	44	56	62
	H	0		2	3	4	5	6	8	9	10	11	12	13	15
Ağırlık Weight	Kg	0,7	0,8	1,2	1,5	2,3	3,5	4,1	7	12	18	22	25	30	40